

RASTO IDENTIFICATION CHART

THIS CHART WILL ASSIST ORDER PREPARATION FOR SYSTEM COMPONENTS. WHEN PLACING AN ORDER EITHER BY MAIL OR BY PHONE, PLEASE IDENTIFY EACH COMPONENT BY ITS CORRECT NAME AND PRODUCT CODE NUMBER. SHOULD YOU HAVE QUESTIONS ABOUT AVAILABILITY OF A SPECIAL PRODUCT, PLEASE CONTACT YOUR ACCOUNT MANAGER OR SYMONS DISTRIBUTION CENTER.

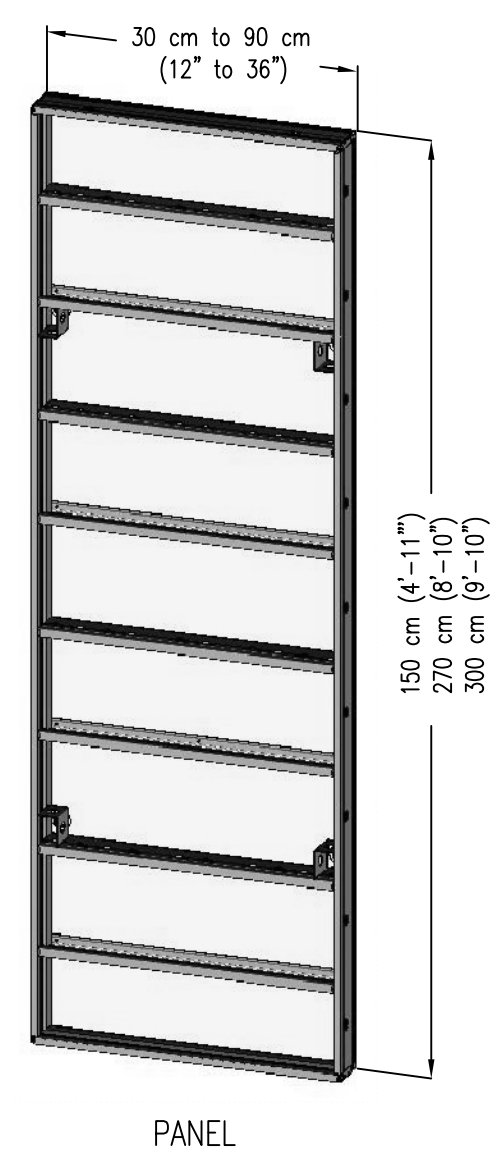

PANEL

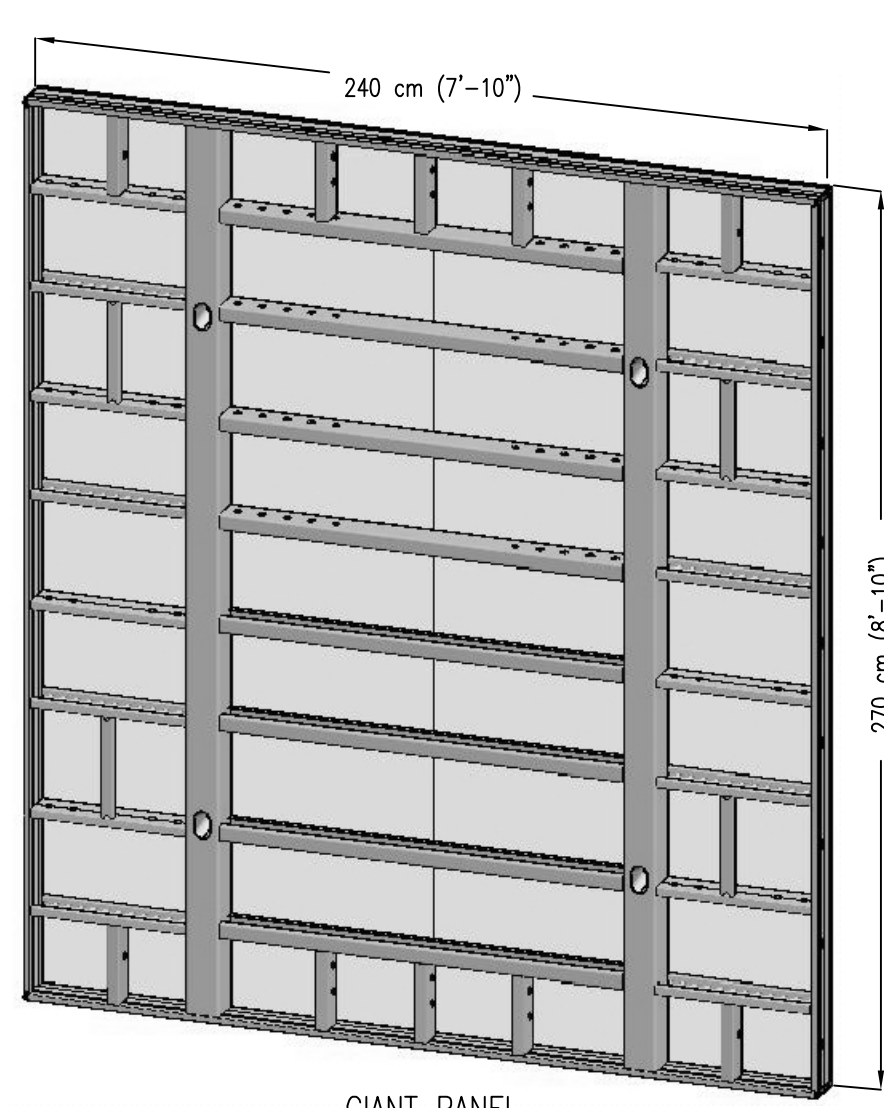

GIANT PANEL

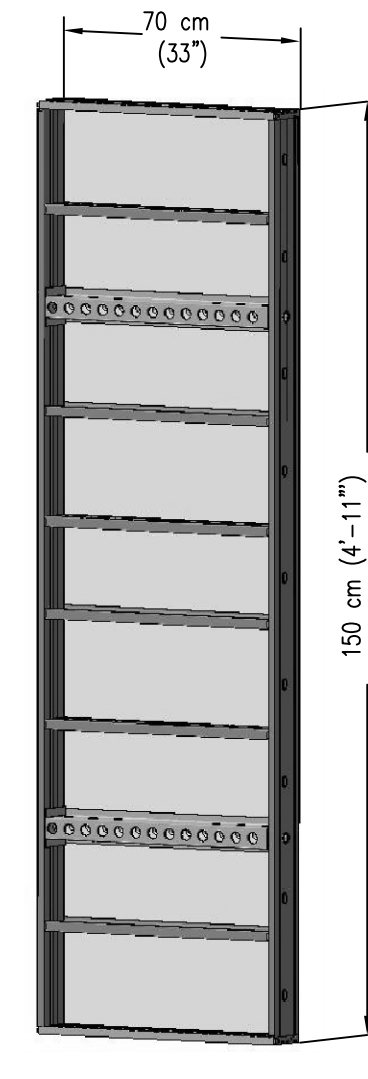

MULTI-PURPOSE PANEL

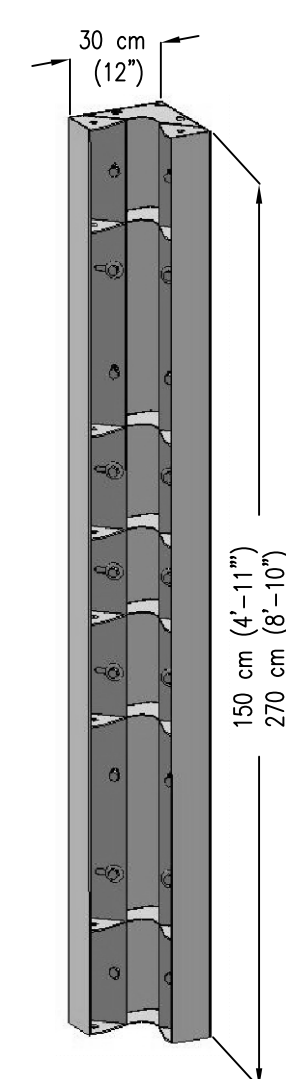

3 PIECE STRIPPING CORNER

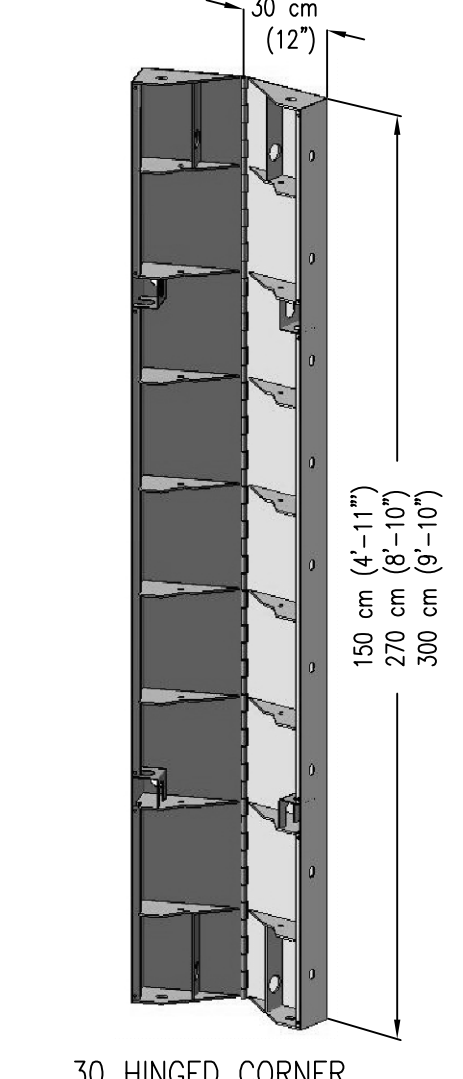

30 HINGED CORNER
RASTO Steel Faced Hinged Corner
RASTO Plywood faced Hinged Corner

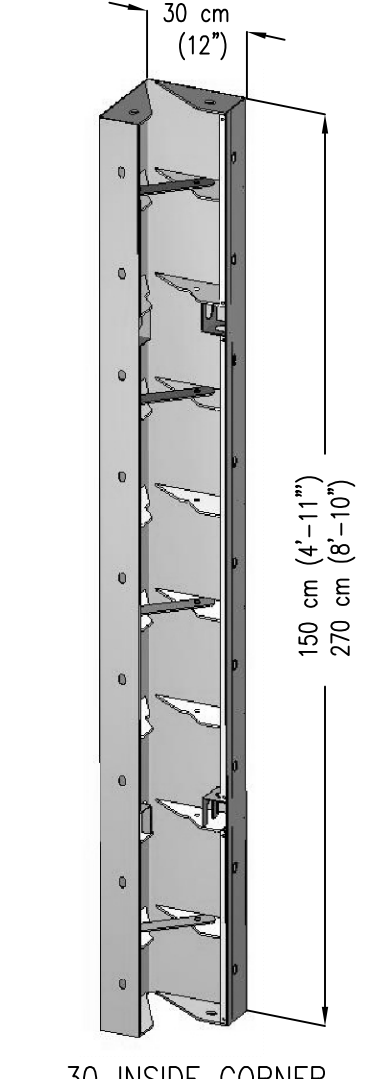

30 INSIDE CORNER
RASTO Steel Faced Inside Corner
RASTO Plywood faced Inside Corner

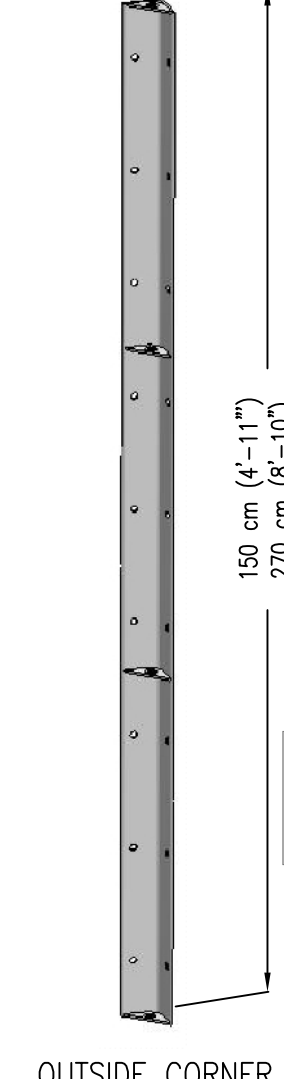

OUTSIDE CORNER

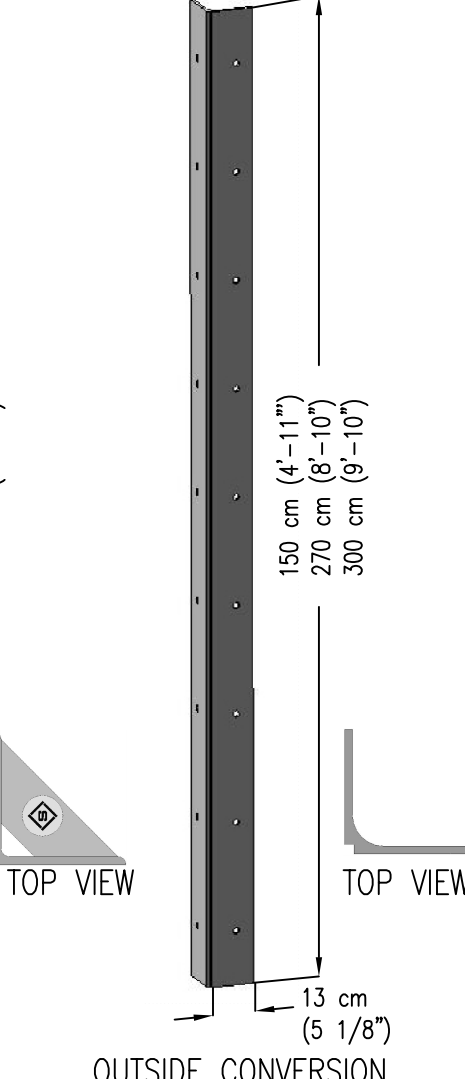

OUTSIDE CONVERSION CORNER (ALUMINUM)

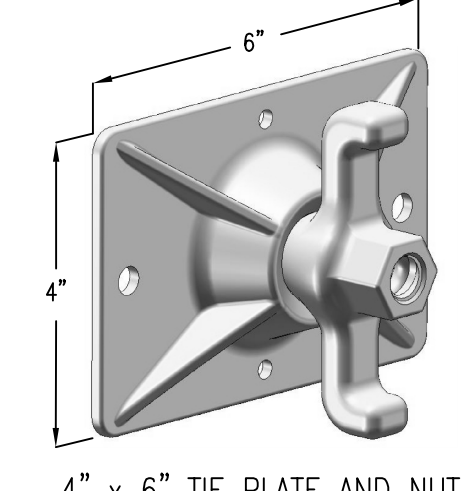

4" x 6" TIE PLATE AND NUT

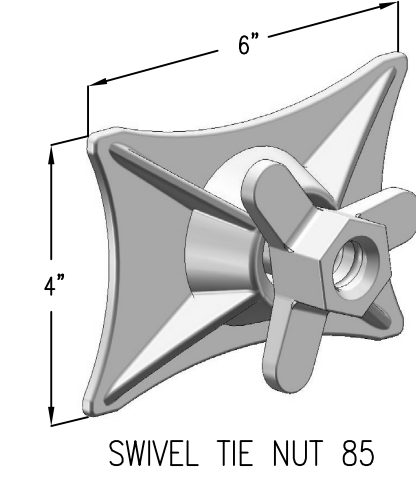

SWIVEL TIE NUT 85

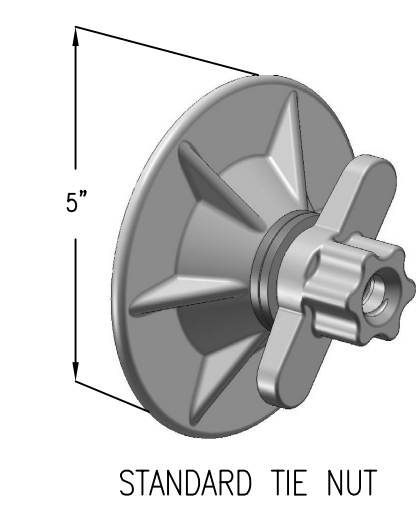

STANDARD TIE NUT

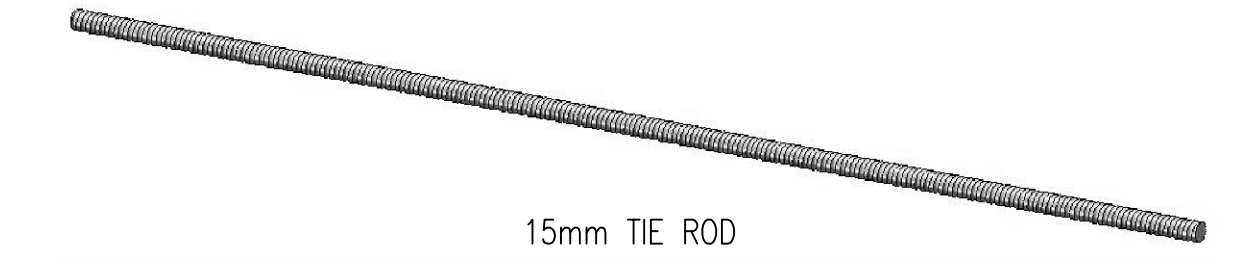

15mm TIE ROD

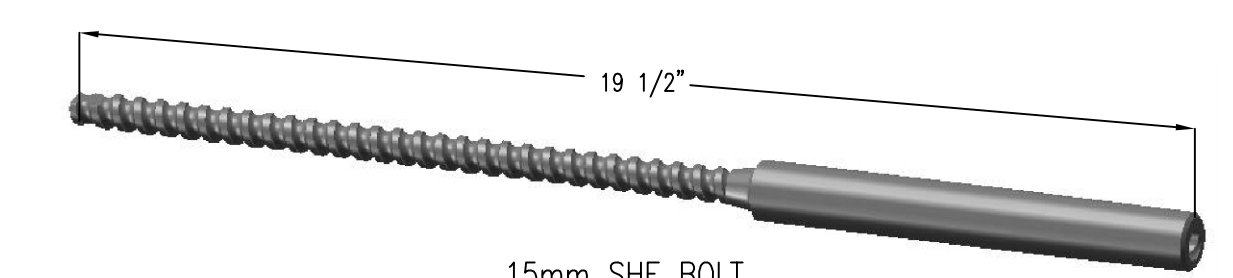

15mm SHE BOLT

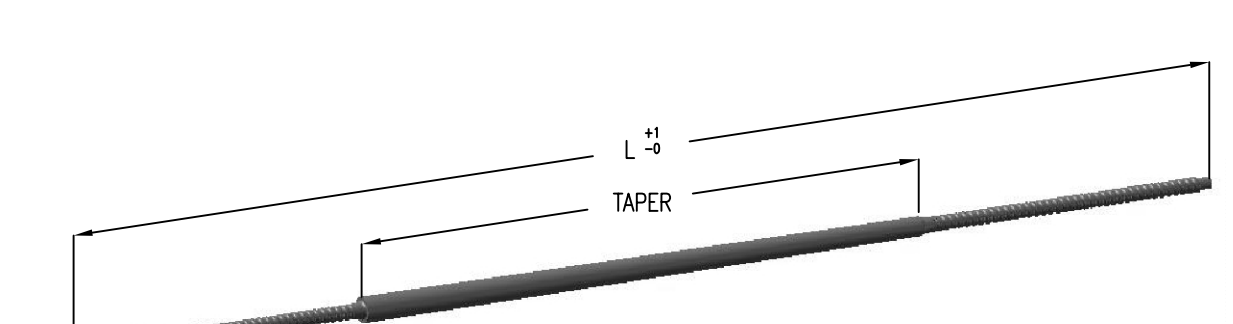

15mm X L TAPER TIE
1" Dia. TO 3/4" Dia.
(For P.C. and Wt. See Chart)

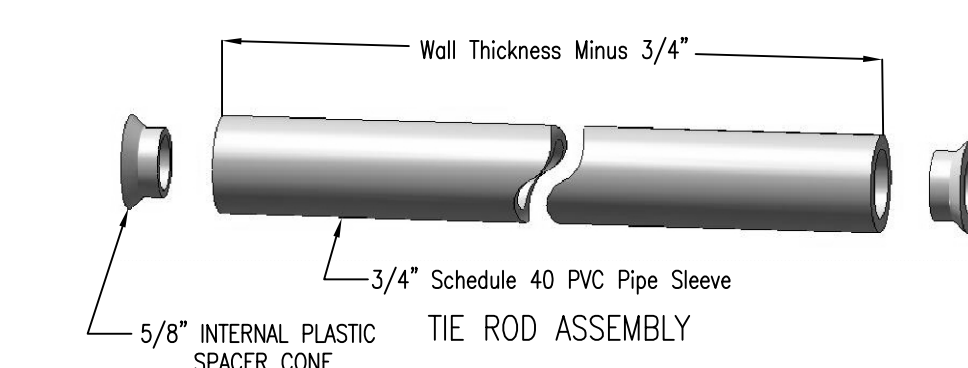

TIE ROD ASSEMBLY

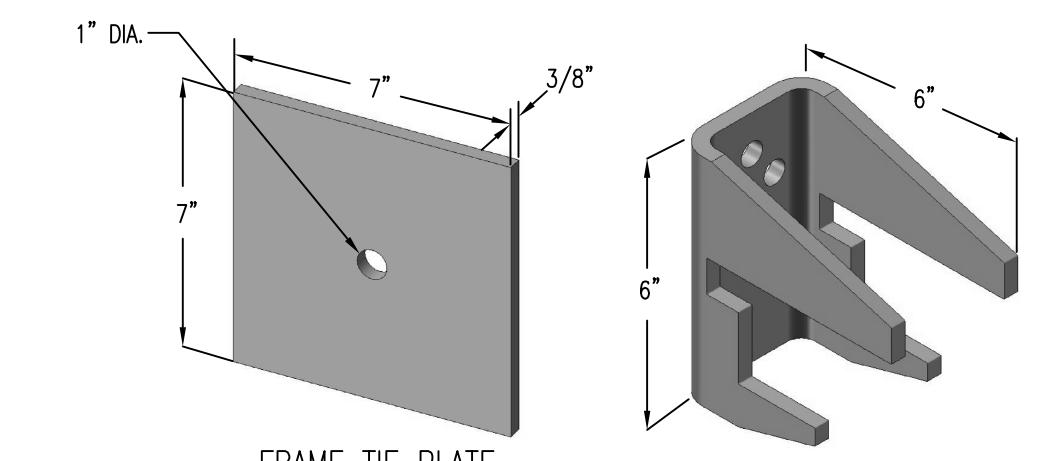

FRAME TIE PLATE
TOP TIE HOLDING CLIP

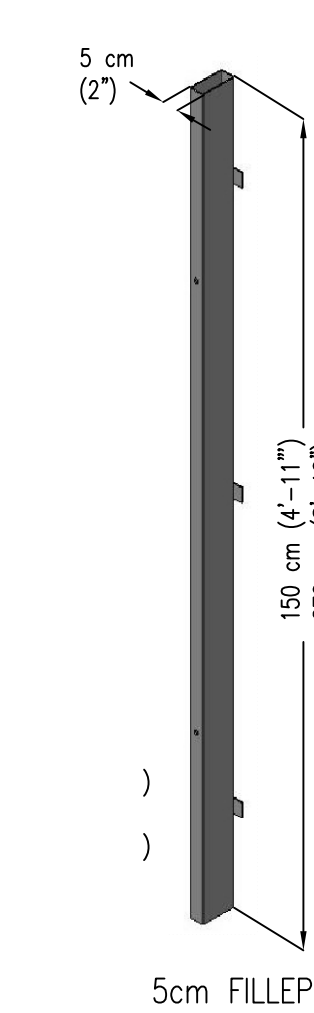

5cm FILLEP

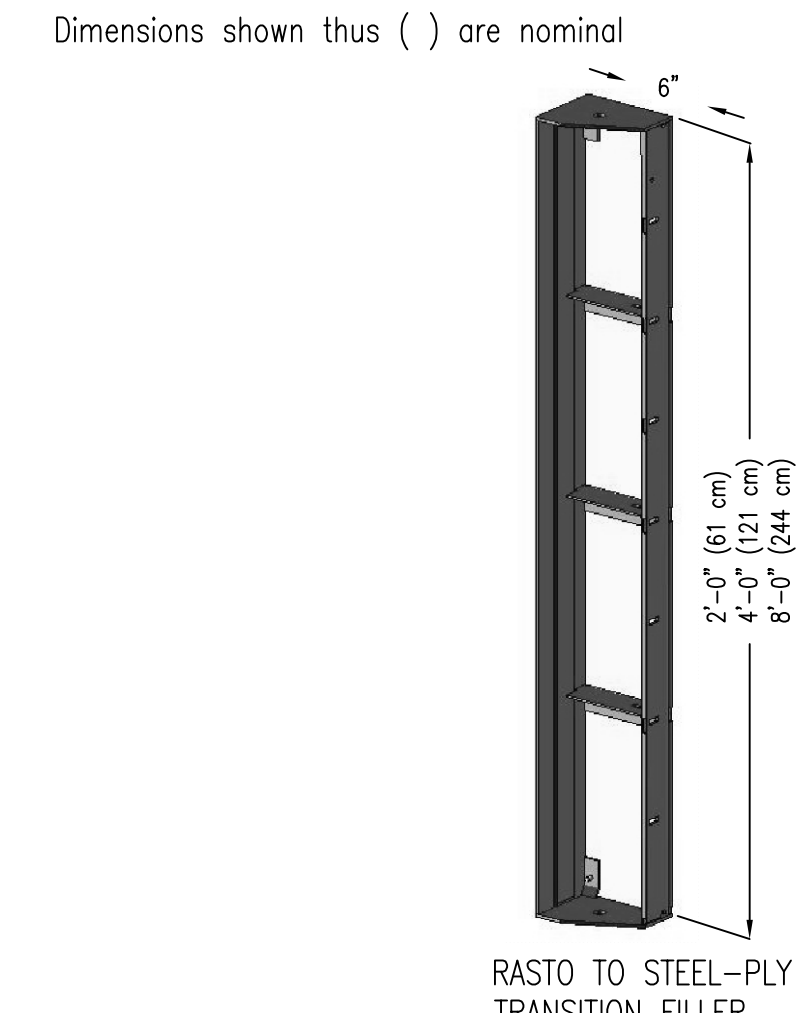

RASTO TO STEEL-PLY TRANSITION FILLER

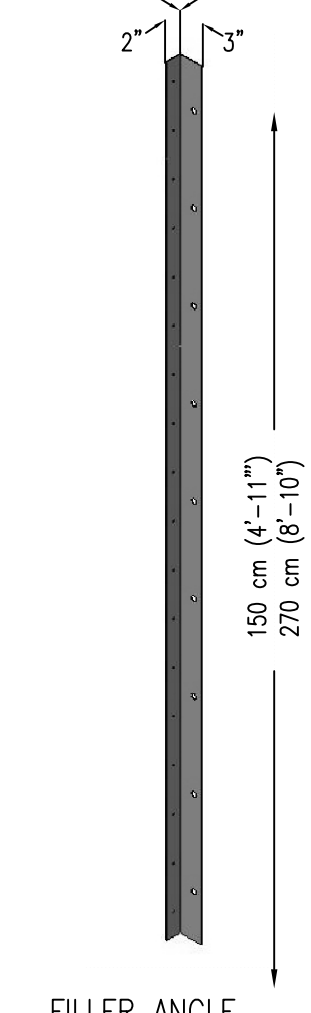

FILLER ANGLE

Dimensions shown thus () are nominal

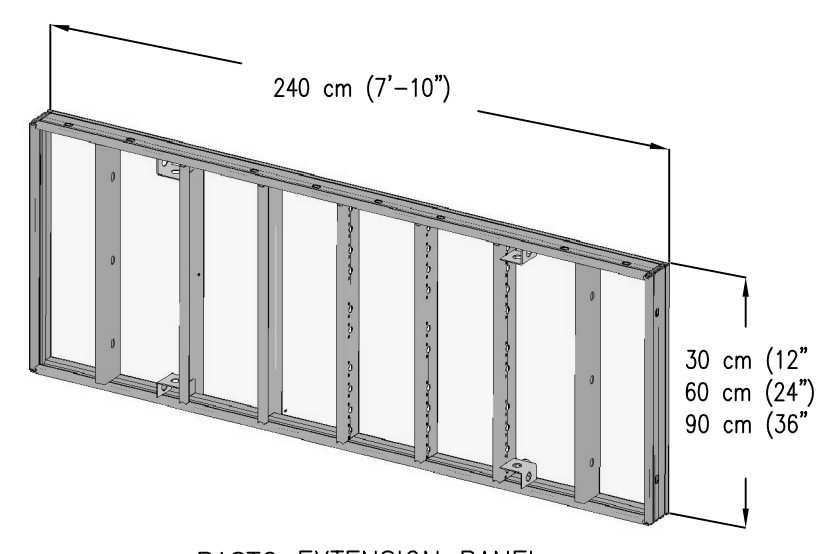

RASTO EXTENSION PANEL

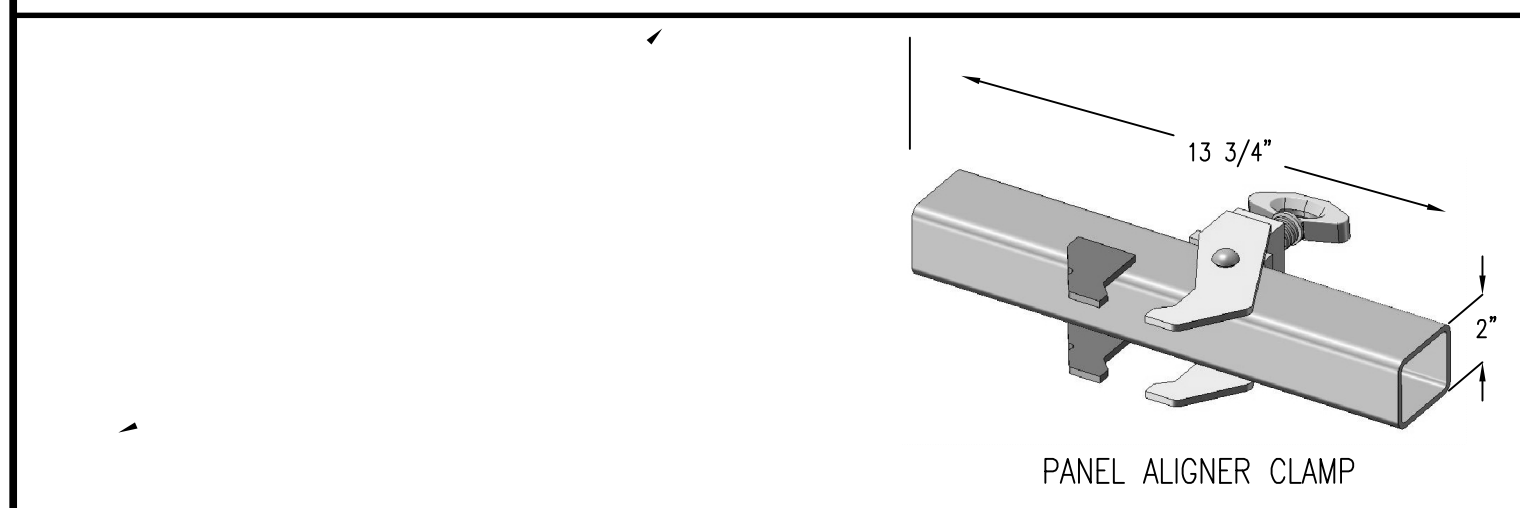

PANEL ALIGNER CLAMP

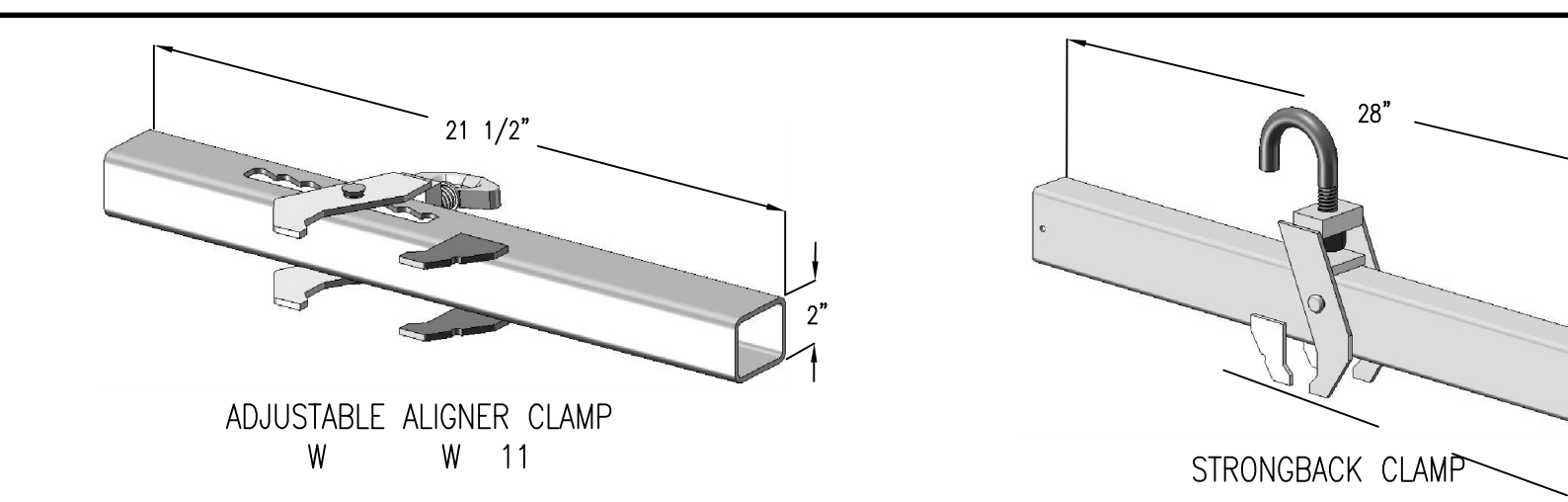

ADJUSTABLE ALIGNER CLAMP

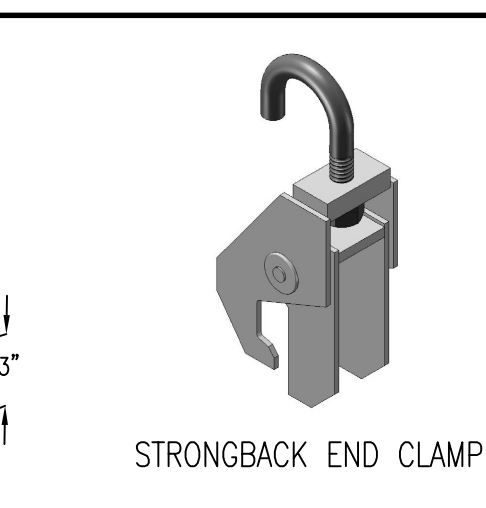

STRONGBACK CLAMP

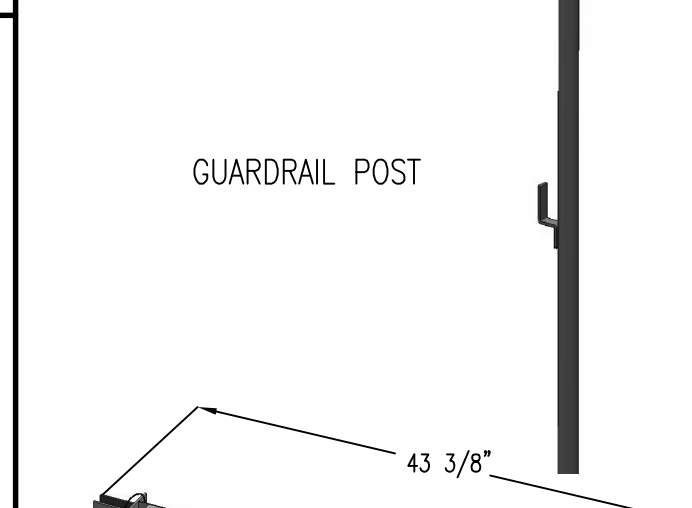

STRONGBACK END CLAMP

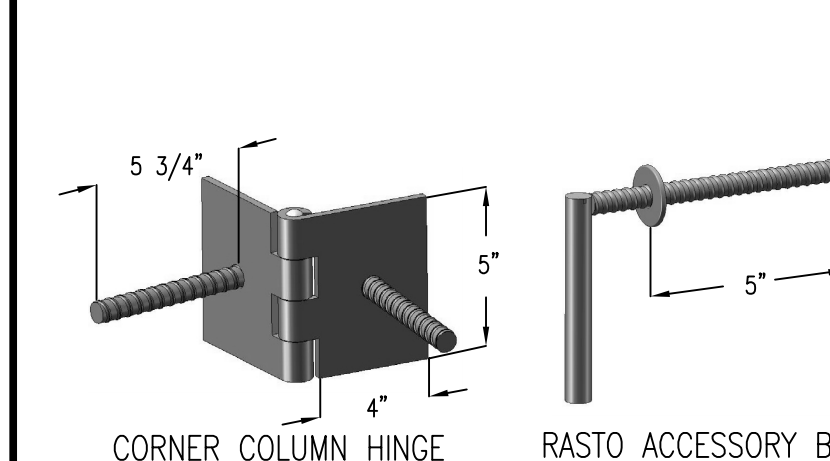

CORNER COLUMN HINGE

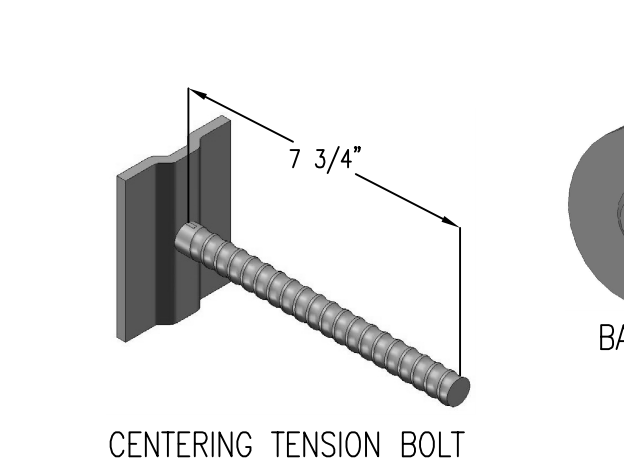

RASTO ACCESSORY BOLT

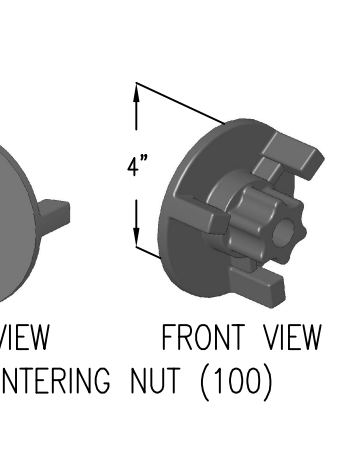

CENTERING TENSION BOLT

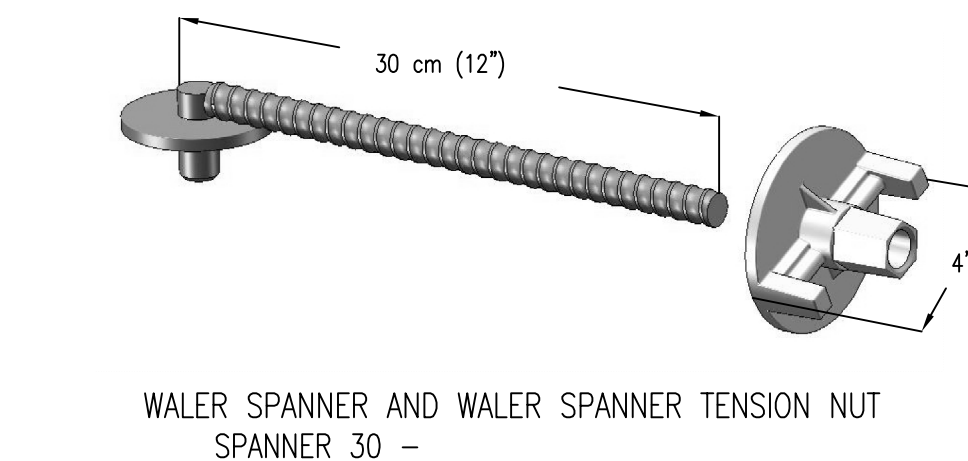

WALER SPANNER AND WALER SPANNER TENSION NUT
SPANNER 30 -
SPANNER 50 -
SPANNER NUT -

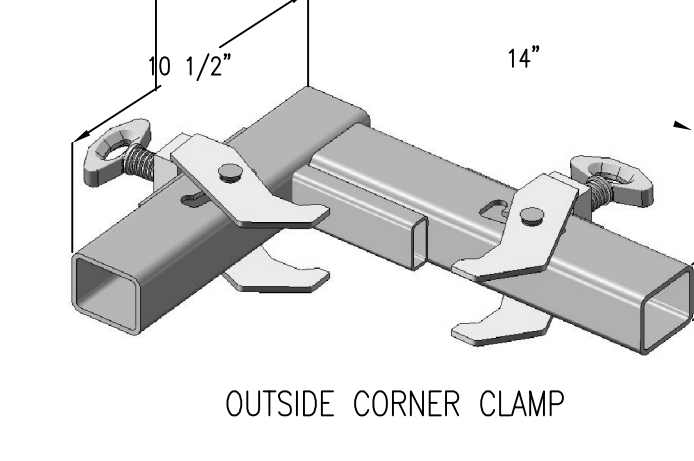

OUTSIDE CORNER CLAMP

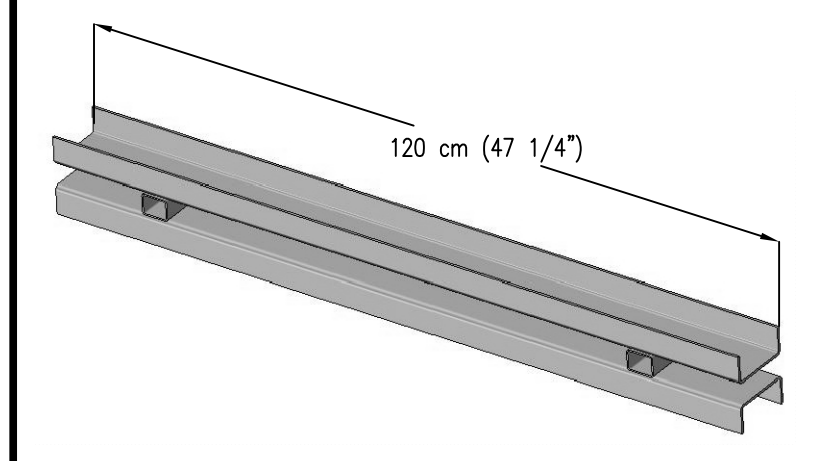

ADJUSTMENT WALER (120)

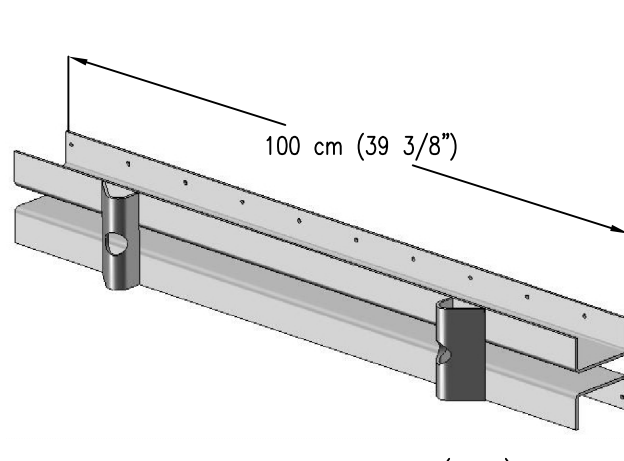

WALER MULTI-PURPOSE (100)

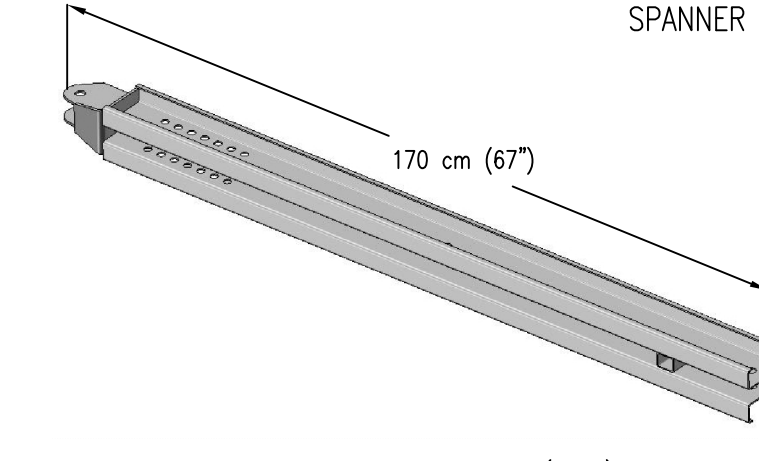

HINGED WALER (170)

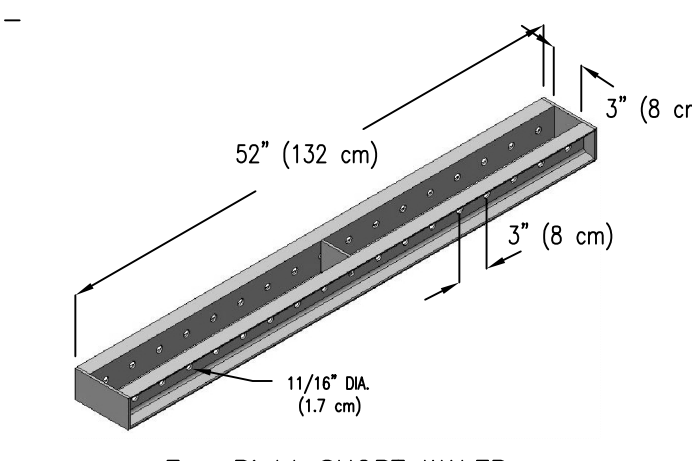

FormRight SHORT WALER

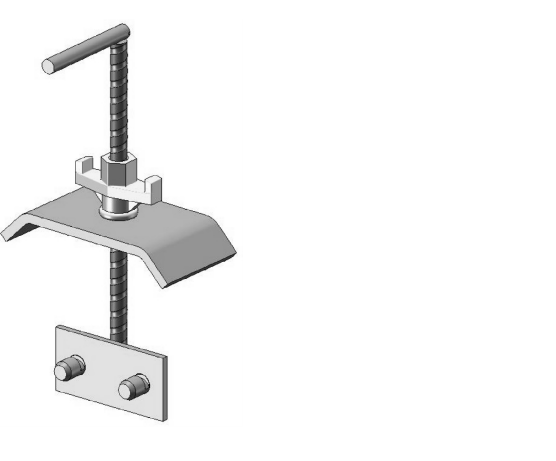

SHORT WALER HARDWARE

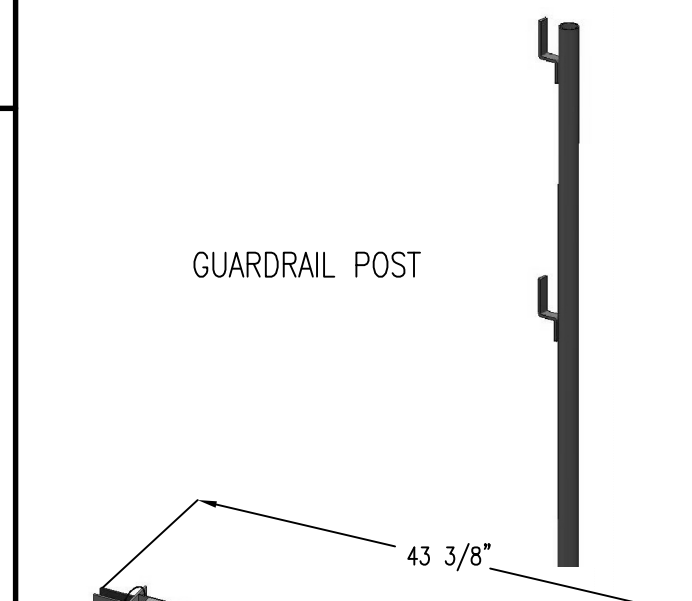

GUARDRAIL POST



WALKWAY BRACKET

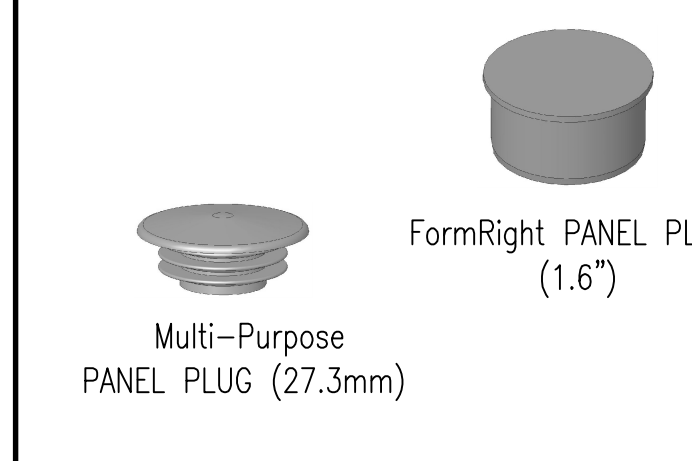

RASTO PANEL PLUG (28.8mm)
Multi-Purpose PANEL PLUG (27.3mm)

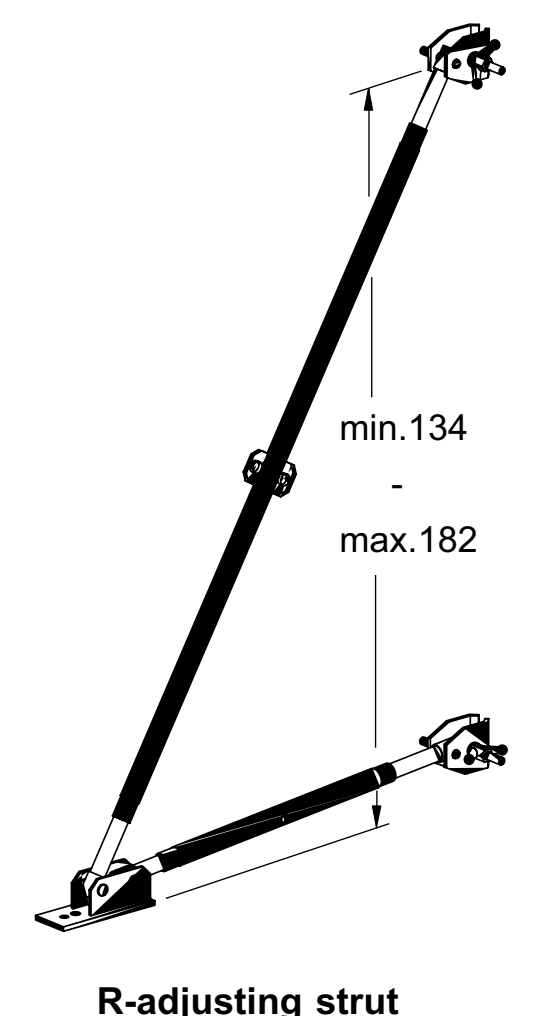

R-adjusting strut

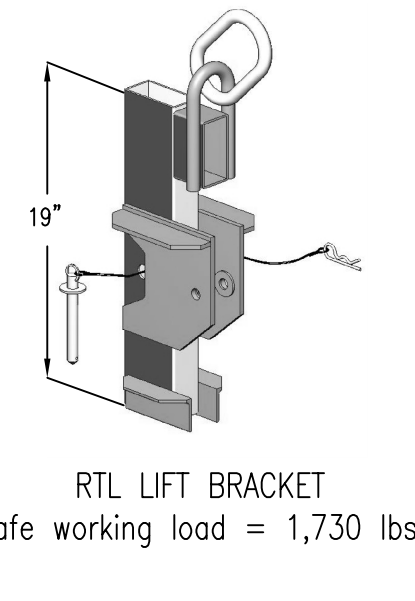

RTL LIFT BRACKET
Safe working load = 1,730 lbs.)

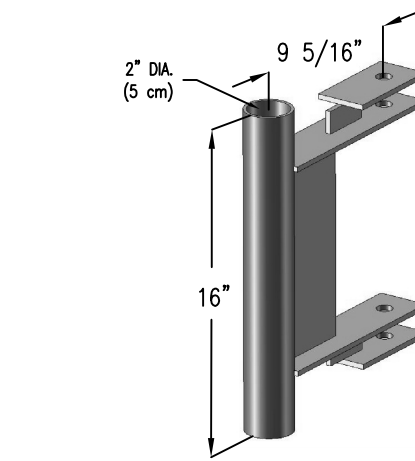

LEVELING DEVICE

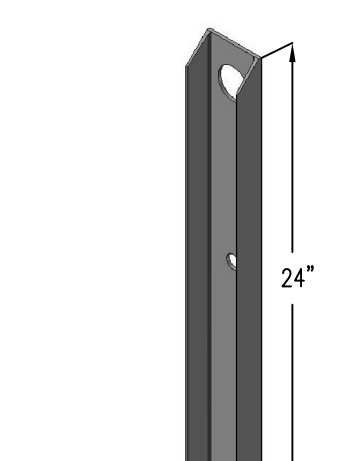

COLUMN LIFT BRACKET



AP/FR HANDLING HOOK



HUCCO BOLT

RASTO
DESUTA CONCRETE FORMS
120 FISHER ROAD
PORTERSVILLE, PA 16051
724-368-3230

